



# OPERATOR/SERVICE MANUAL

MODELS/MANUAL: RD24HT, RD33HT, RDS33HT

MODELS/REMOTE: RD24HTR, RD33HTR, RDS33HTR



## BULLDOG® Trench Roller

Stone Construction Equipment, Inc.  
P.O. Box 150, Honeoye, New York 14471  
Phone: (800) 888-9926  
Fax: 716-229-2363  
E-Mail: [SCENY@MCIMAIL.COM](mailto:SCENY@MCIMAIL.COM)  
www: [stone-equip.com](http://stone-equip.com)

A 100% employee-owned American manufacturer  
© 1989 Stone Construction Equipment, Inc.  
Printed in U.S.A.

## Exploded Diagrams and Parts List

Upper Frame .....	40 - 41
Lower Frame .....	42 - 43
Control Levers .....	44 - 45
Throttle Assembly .....	46 - 47
Ignition Box Assembly .....	48 - 49
Hatz Twin Engine .....	50 - 51
Piping Diagram Manual Machine .....	52 - 53
Piping Diagram Remote Machine .....	54 - 55
Hatz Wire Diagram Manual Machine .....	56
Hatz Wire Diagram Remote Machine .....	57
Manifold Wire Diagram Remote Machine .....	58 - 59
Hydraulic Diagram Manual Machine .....	60 - 61
Hydraulic Diagram Remote Machine .....	62 - 63
Remote Transmitter/Receiver .....	64 - 65
Decals .....	66 - 67

# Upper Frame Assembly

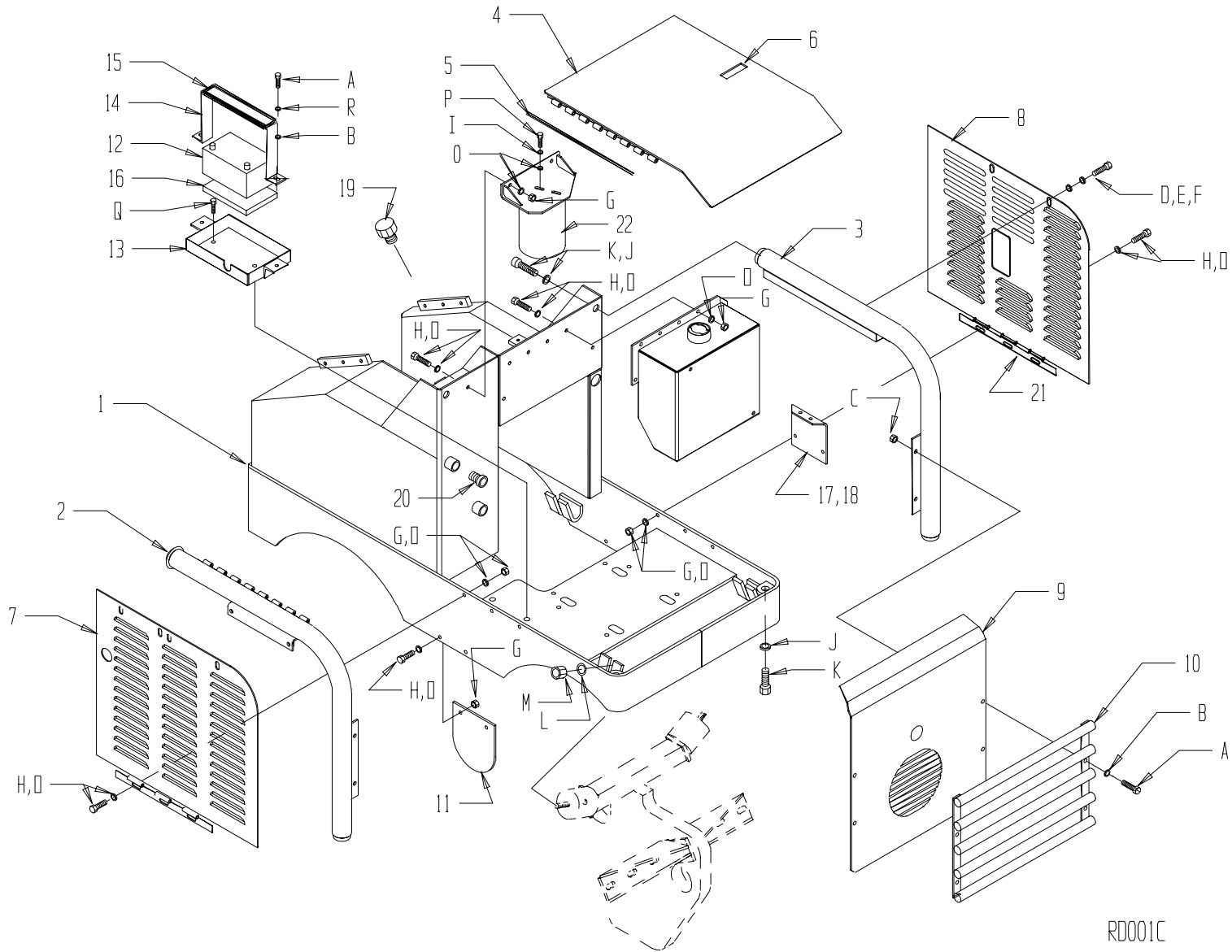

R0001C

## Upper Frame Assembly Parts List

Item	Part No.	Description	Qty.	Item	Part No.	Description	Qty.	Torque (Ft. Lbs.)
1	43700-Yel	Frame Weld Upper	1	A*	80145	HHCS 3/8-16 X 1-1/4 GR5 ZN	4	23
2	42884-Yel	Rollbar RH	1	B	80342	WSHR 3/8 SAEZN	4	-
3	43719-Yel	Rollbar LH	1	C	80056	NUTNY 3/8 - 16 ZN	4	-
4	43718-Gry	Cover Weld Hatz	1	D	80665	HHCS 3/8-16 X 1 SS	4	23
5	42483	Pin Cover	1	E	80666	WSHR 3/8 FLAT SS	4	-
6	41030	Latch Cover	1	F	80058	WSHRL 3/8 SPLIT ZN	4	-
7	42962-Gry	Shield Side RH	1	G	80114	NUTNY 5/16 - 18 ZN	14	-
8	42963-Gry	Shield Side LH	1	H*	80161	HHCS 5/16 - 18 X 1 GR5 ZN	14	13
9	43728-Gry	Panel Front	1	I	80086	WSHRL 5/16 SPLIT ZN	4	-
10	42559-Gry	Guard Weld Brush	1	J	80671	WSHRL 3/4 SPLIT ZN	4	-
11	42045-Gry	Guard Ecc Motor	1	K*	80753	SHCS 3/4-10 X 1-1/4 BLK	4	200
12	36319	Battery	1	L	80118	WSHR 1/2 WROT	6	-
13	43695-Yel	Box Weld Battery	1	M*	80537	NUTFL 1/2-20 ZN	6	90
14	43697-Yel	Strap Battery	1	O	80348	WSHR 5/16 WROT ZN	26	-
15	38828	Wrap Strap Poly	1	P*	80159	HHCS 5/16 - 18 X 3/4 GR5 ZN	4	13
16	47392	Liner Battery	1	Q*	80649	BHSCS 3/8 - 16 X 3/4 BLK	2	23
17	43019-Gry	Bracket Filter/Sep	1	R	80058	WSHRL 3/8 SPLIT ZN	2	-
18	43020-Gry	Strap Filter/Sep	1					
19	38521	Breather	1					
20	38534	Sight Glass	1					
21	38802	Hinge	2					
22	38636	Filter Assembly	1					
	38638	Element Only	1					

**REMARK:** \* Loctite required.

# Lower Frame Assembly

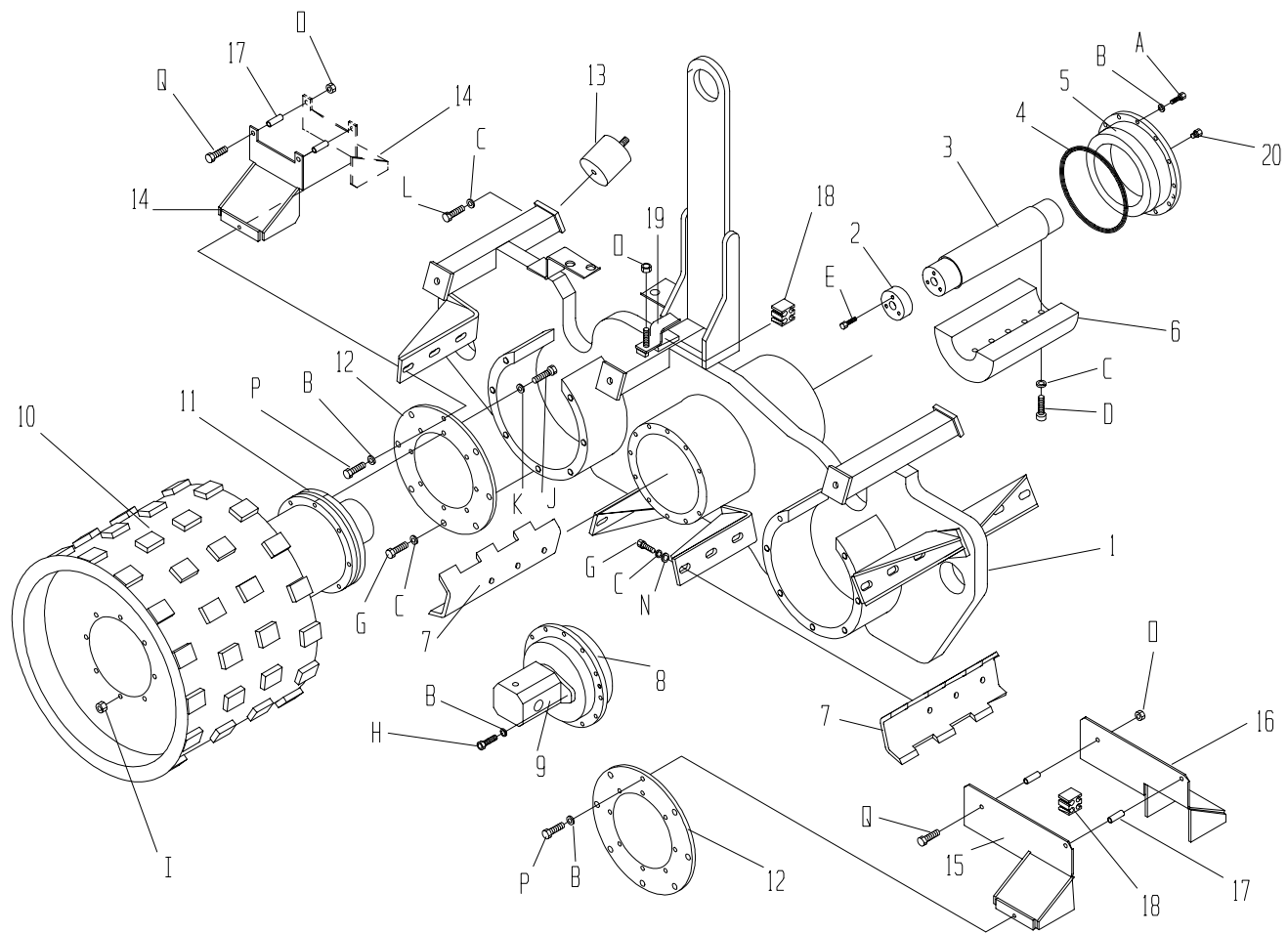

RD002B

## Lower Frame Assembly Part Numbers

Item	Part No.	Description	Qty.	Item	Part No.	Description	Qty.	Torque (Ft. Lbs.)
1	42936-2	Frame Weld Lower	1	A*	80702	HHCS 3/8-16 X 1-1/4 GR 5 ZN	24	23
2	29266	Eccentric Extension	1	B	80058	WSHRL 3/8 MED SPLIT ZN	30	-
3	42306	Eccentric Shaft	1	C	80117	WSHRL 1/2 MED SPLIT ZN	79	-
4	32216	O-Ring 8 Nom ID	2	D*	80662	SHCS 1/2-13 X 2-1/4 BLK	5	80
5	22706-2	Bearing/Endcap Assembly	1	E*	80049	SHCS 5/16-18 X 1-1/4 BLK	3	18
6	42307	Eccentric Weight	1	G*	80703	HHCS 1/2-13 X 1-1/2 GR5 ZN	68	57
7	42204-2	Scraper Wide	8	H*	80101	SHCS 3/8-16 X 1-1/4 BLK	2	23
	42205-2	Scraper Narrow	8	I*	80650	LUGNUT 9/16 ZN	32	122
	42206-2	Scraper Smooth	8	J*	80203	HHCS 5/8-11 X 1-1/4 GR 5 ZN	24	159
8	22707-2	Bearing/Motorcap Assembly	1	K	80337	WSHRL 5/8 MED SPLIT ZN	24	-
9	30271	Eccentric Motor	1	L*	80645	HHCS 1/2-20 X 1 GR 5 BLK	6	90
	47301	O-Ring	1	N	80118	WSHR 1/2 WROT ZN	24	-
10	29766-2	Wide Drum	4	O	80114	NUTNY 5/16-18 ZN	5	-
	29968-2	Narrow Drum	4	P*	80174	HHCS 3/8-16 X 1 GR8 ZN	4	23
	29971-2	Smooth Drum	4	Q*	80579	HHCS 5/16 X 2-1/4 GR5 ZN	4	13
11	30557-2	Wheel Motor	4					
12	29765-2	Hub Plate	4					
13	47281	Shock	6					
14	42907-2	Hose Guard Rear	2					
15	42908-2	Hose Guard Front RH	1					
16	42910-2	Hose Guard Front LH	1					
17	42920-2	Spacer Captivator	4					
18	39034	Captivator Tubing	2					
19	42875-2	Clamp Captivator	1					
20	46638	Plug O-Ring 3-4-16	1					

REMARK: \* Loctite required.

# Control Levers Assembly

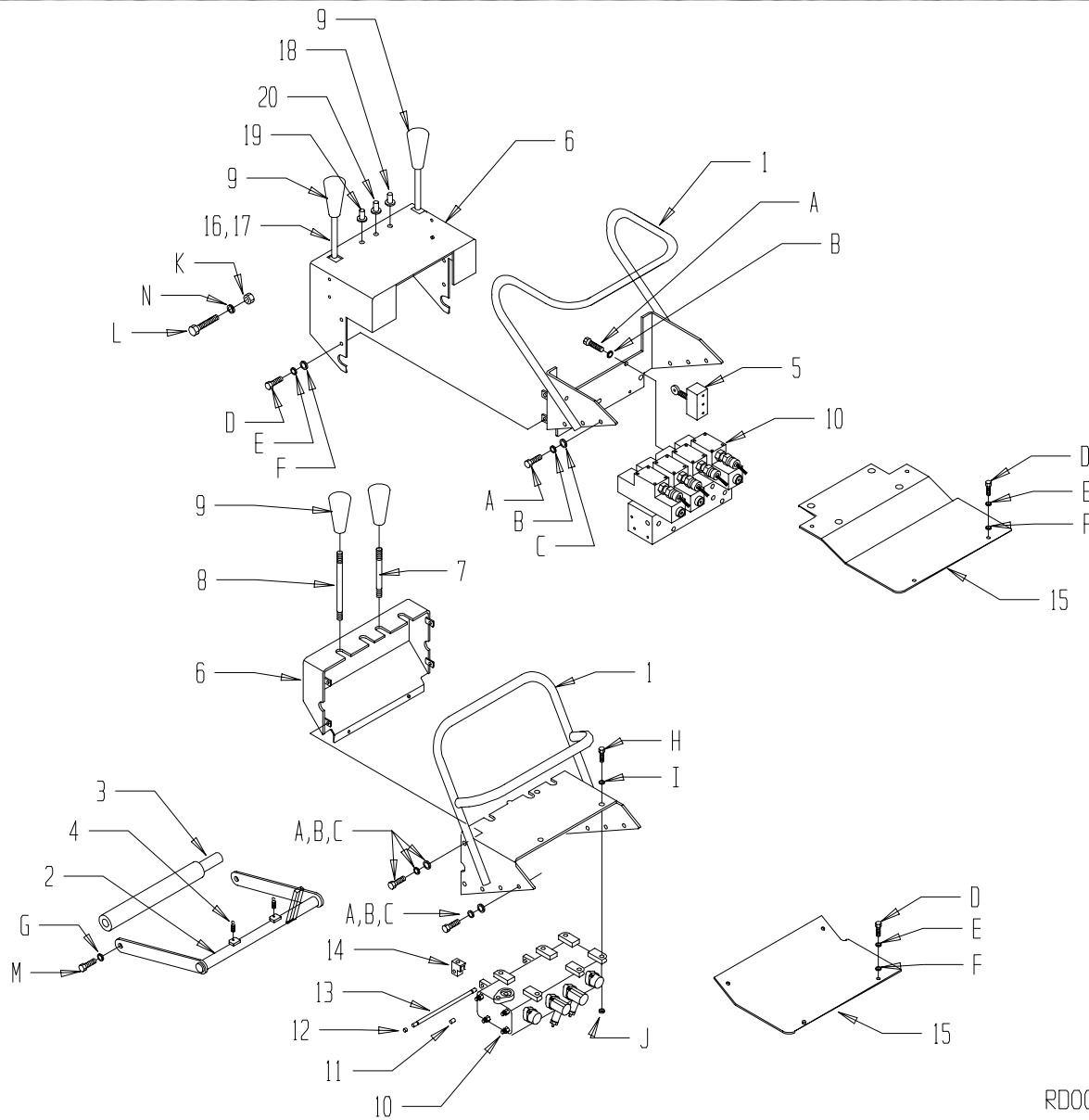

R00030

## Control Levers Assembly Parts List

Item	Part No.	Description	Qty.	Item	Part No.	Description	Qty.	Torque (Ft. Lbs.)
1	43709-Gry	Handle (Manual)	1	A*	80686	HHCS 3/8 -16 X 3/4 GR8 ZN	19	33
	43705-Gry	Handle (Remote)	1	B	80058	WSHRL 3/8 MED SPLIT ZN	23	-
2	43129-Gry	Crush Bar Weld (Manual)	1	C	80755	WSHR 3/8 ZN	15	-
	22938-Gry	Crush Bar Weld (Remote)	1	D*	80161	HHCS 5/16 -18 X 1 GR5 ZN	14	13
3	43095	Handle Crush Bar	1	E	80086	WSHRL 5/16 MED SPLIT ZN	20	-
4	39008	Spring Crush Bar	2	F	80348	WSHR 5/16 WROT ZN	12	-
5	36290	Switch Safety (Remote Only)	1	G	80666	WSHR 3/8 FLAT SS	2	-
6	43734-Gry	Cover Weld Rear (Manual)	1	H*	80190	HHCS 7/16 -20 X 1-1/2 GR5 ZN	3	41
	22934-Gry	Cover Weld Rear (Remote)	1	I	80335	WSHRL 7/16 MED SPLIT ZN	3	-
7	42136	Lever Ecc/Speed (Manual)	2	J	80249	NUTFX 7/16-20	3	-
8	42135	Lever Driver (Manual)	2	K	80236	NUTKP1/4-20	4	-
9	47298	Knob (Manual)	4	L	80781	HHCS1/4-20 X 3-1/4	4	-
	47286	Knob (Remote)	2	M*	80093	SHSHB 3/8 X 3/4 BLK	2	25
10	38668	Manifold (Manual)	1	N	80571	WSHR 1/4 SAE ZN	4	-
	39306	Manifold (Remote)	1					
11	38678	Pin Clevis (Manual Only)	4					
12	38857	Clip Retaining (Manual Only)	1					
13	38679	Rod Fulcrum (Manual Only)	1					
14	38677	Pivot Handle (Manual Only)	1					
15	42852-Gry	Cover Hoses (Manual )	1					
	43707-Gry	Cover Hoses (Remote)	1					
16	48310	Switch/Lever F/R RH (Remote Only)	1					
17	48354	Switch/Lever F/R LH (Remote Only)	1					
18	36301	Switch Ecc F/R (Remote Only)	1					
19	48296	Switch Hi/Lo (Remote Only)	1					
20	48374	Switch REM/MAN (Remote Only)	1					
	35838	Boot Rubber	3					

**REMARK:** \* Loctite required.



# Throttle Assembly

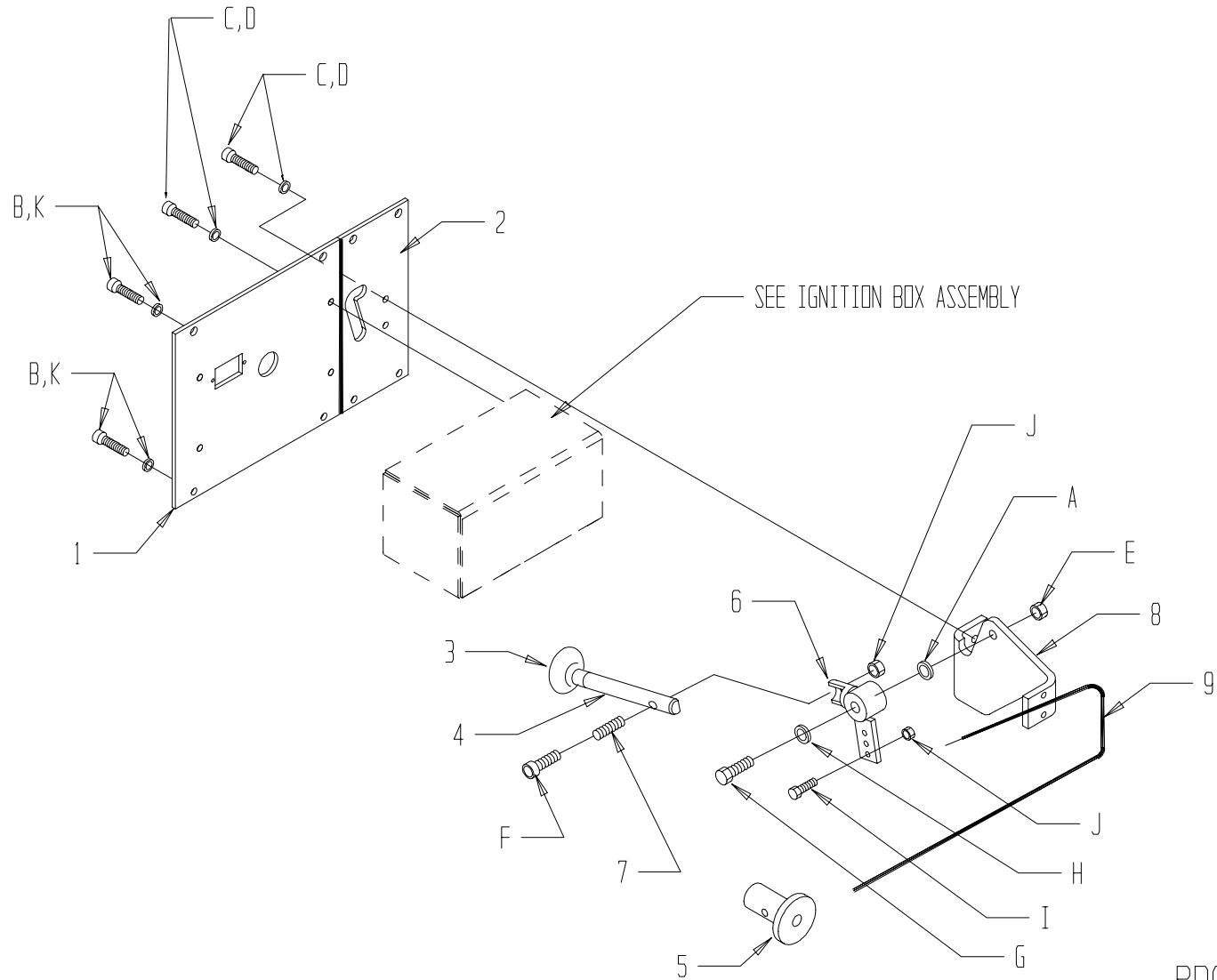

RD004B

## Throttle Assembly Parts List

Item	Part No.	Description	Qty.	Item	Part No.	Description	Qty.	Torque (Ft. Lbs.)
1	43703-Yel	Panel Control	1	A	80342	WSHR 3/8 SAE ZN	8	-
2	43704-Yel	Panel Throttle	1	B*	80085	HWHST 5/16-18 X 1 ZN	8	13
3	27363	Knob Throttle	1	C*	80757	BHSCS 1/4-20 X 3/4 BLK	6	6
4	42919-2	Lever Throttle	1	D	80116	WSHRL 1/4 SPLIT ZN	6	-
5	41006	Clamp Throttle	1	E	80244	NUTFX 5/16-18 ZN	1	-
6	42915-2	Pivot Throttle	1	F*	80756	SHSHB 1/4 X 1-1/4 BLK	1	6
7	42961	Spring Compression	1	G*	80124	SHSHB 3/8 X 1 BLK	1	13
8	42857-2	Bracket Throttle	1	H	80755	WSHR 3/8 BELLEVILLE	1	-
9	39053	Cable Throttle	1	I*	80754	BHSCS 10-24 X 1 BLK	1	6
				J	80693	NUTNY 10-24 ZN	2	-
				K	80348	WSHR 5/16 WROT ZN	8	-

**REMARK:** \* Loctite required.

# Ignition Box Assembly

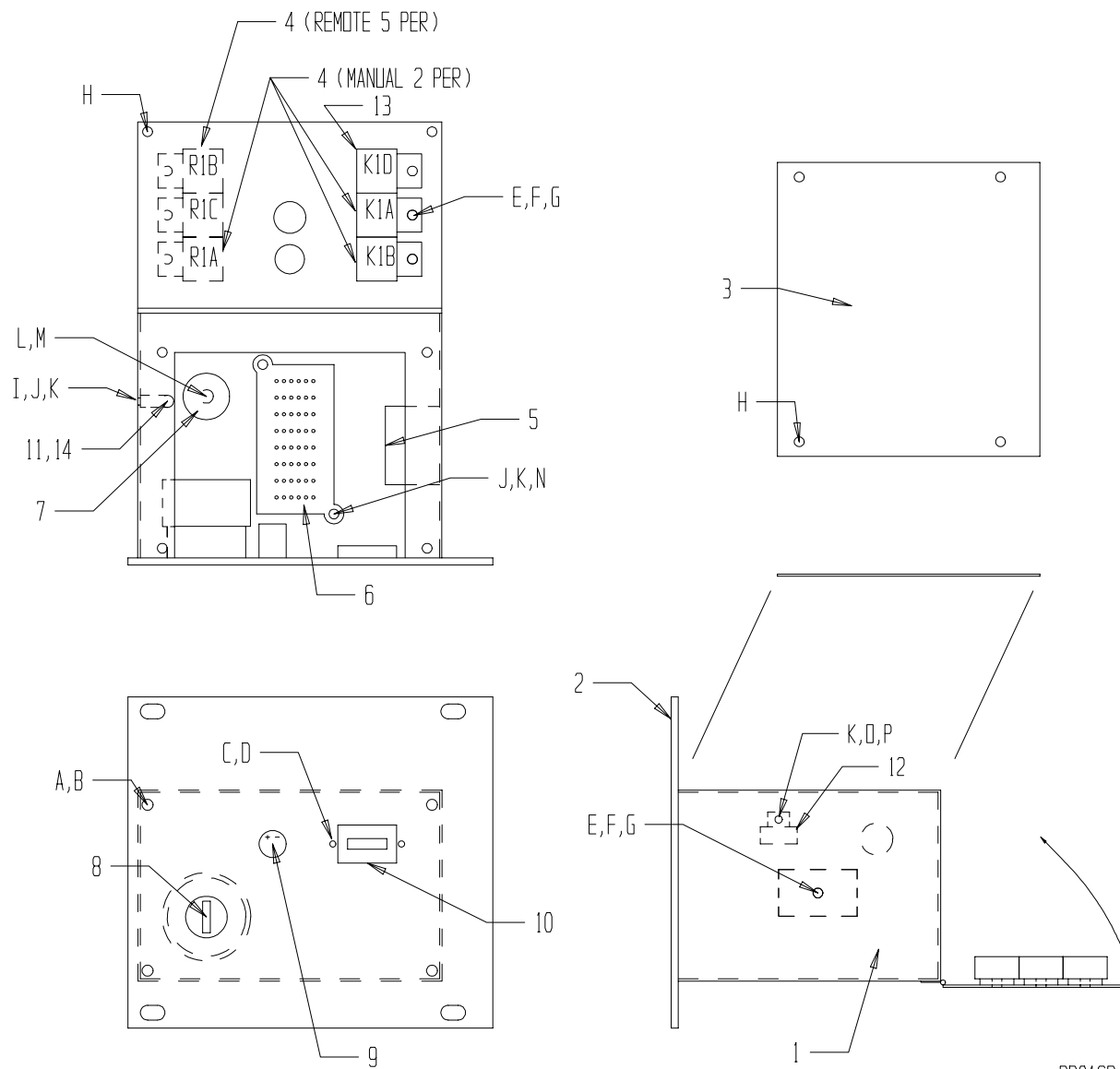

R0016B

## Ignition Box Assembly Parts List

Item	Part No.	Description	Qty.	Item	Part No.	Description	Qty.	Torque (Ft. Lbs.)
	<b>48375</b>	<b>Box Assy Ignition Remote</b>			<b>48376</b>	<b>Box Assy Ignition Manual</b>		
1	43993	Ignition Box Enclosure Blk	1	1	43713	Ignition Box Enclosure Blk	1	
2	43994	Control Plate Yellow	1	2	43994	Control Plate Yellow	1	
3	43729	Cover Ignition Box Blk	1	3	43729	Cover Ignition Box Blk	1	
4	48378	Relays	5	4	48378	Relays	2	
5	48379	Relay	1	5	48379	Relay	1	
6	48380	Terminal Block	1	6	48380	Terminal Block	1	
7	48381	Capacitor	1	7	48381	Capacitor	1	
8	36307	Key Switch	1	8	36307	Key Switch	1	
	38629	Key	1		38629	Key	1	
9	48382	Battery Lamp	1	9	48382	Battery Lamp	1	
10	38782	Hour Meter	1	10	38782	Hour Meter	1	
11	36389	Tipover Switch	1	11	36389	Tipover Switch	1	
	36390	Clamp	1	13	48401	Relay 70A	1	
12	48389	Circuit Breaker 15A	1	14	36401	Base	1	
13	48401	Relay 70A	1		36402	Tie Wrap	1	
A	80757	BHSCS 1/4 - 20 x 3/4 Blk	4	A	80757	BHSCS 1/4 - 20 x 3/4 Blk	4	
B	80116	WSHRL 1/4 SPLIT ZN	4	B	80116	WSHRL 1/4 SPLIT ZN	4	
C	80916	SHCS 6-32 x 1/2 Blk	2	C	80916	SHCS 6-32 x 1/2 Blk	2	
D	80339	WSHRL #6 MED SPLIT ZN	2	D	80339	WSHRL #6 MED SPLIT ZN	2	
E	80227	RHMS 10-24x 3/8 ZN	7	E	80227	RHMS 10-24x 3/8 ZN	7	
F	80917	WSHRL #10 STAR EXT ZN	7	F	80917	WSHRL #10 STAR EXT ZN	7	
G	80115	NUTFX 10-24 ZN	7	G	80115	NUTFX 10-24 ZN	7	
H	80918	BHSMS 10-32 x 3/8 ZN	6	H	80918	BHSMS 10-32 x 3/8 ZN	6	
I	80141	RHSMS 8-32 x 3/8 ZN	1	I	80141	RHSMS 8-32 x 3/8 ZN	1	
J	80919	WSHRL #8 STAR EXT ZN	3	J	80919	WSHRL #8 STAR EXT ZN	3	
K	80219	NUTFX 8-32 ZN	4	K	80219	NUTFX 8-32 ZN	5	
L	80698	NUTFX M8-1.25 8.8 ZN	1	L	80698	NUTFX M8-1.25 8.8 ZN	1	
M	80920	WSHRL 5/16 STAR EXT ZN	1	M	80920	WSHRL 5/16 STAR EXT ZN	1	
N	80921	RHSMS 8-32 x 1 ZN	2	N	80921	RHSMS 8-32 x 1 ZN	2	
O	80922	BHSMS 8-32 x 3/8 ZN	1					
P	80139	WSHRL #8 MED SPLIT	1					

REMARK:

# Hatz Twin Engine

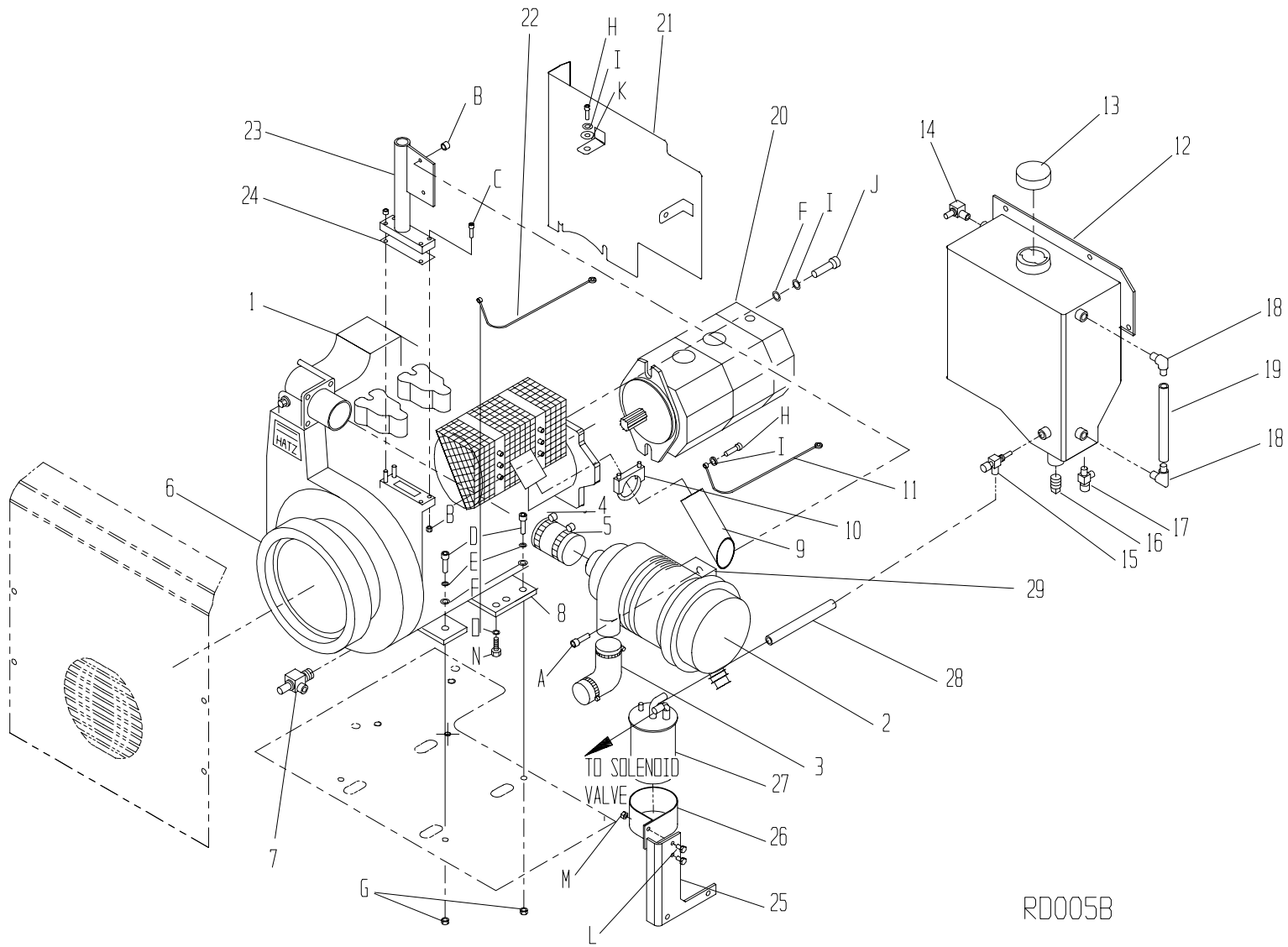

RD005B

## Hatz Twin Engine Parts List

Item	Part No.	Description	Qty.	Item	Part No.	Description	Qty.	Torque (Lb.Ft.)
1	31328	Hatz Twin 20HP	1	26	43020	Water Separator Strap	1	
2	36386	Air Cleaner Assembly	1	27	30345	Water Separator Fuel Filter	1	
	36387	Element	1	28	46186	Hose Fuel Line	9 "	
3	47365	Air Cleaner Hose	1	29	36388-2	Air Cleaner Mounting Bracket	1	
4	35219	Hose Clamp	4					
5	42975	Hose	1	A	80161	HHCS 5/16-18 X 1 GR5 ZN	2	13
6	32276	Front Cowl Seal	1	B	80114	NUTNY 5/16-18 ZN	4	-
7	38680	Oil Drain	1	C	80607	SHCS 5/16 - 18 X 2 BLK	2	25
8	43693	Spacer	1	D*	80094	HHCS 3/8 - 16 X 1-3/4 GR8 ZN	4	33
9	42994	Exhaust Pipe	1	E	80058	WSHRL 3/8 ZN	4	-
10	31223	Clamp Pipe Muffler	1	F	80342	WSHR 3/8 ZN	4	-
11	48367	Cable Battery 24" Blk	1	G	80056	NUTNY 3/8 ZN	4	-
12	42846	Fuel Tank	1	H	61697	SHCS M10 X 25	3	-
13	46059	Cap	1	I	80035	WSHRL 7/16 MED SPLIT ZN	4	-
14	46365	Elbow	1	J	61672	HHCS M10 X 35	2	38
15	46009	Pet Cock	1	K	80043	WSHR 3/8 WROT	3	-
16	46108	Magentic Plug	1	L	80757	BHSCS 1/4 - 20 X .75 BLK	2	6
17	39056	Pet Cock	1	M	80676	NUTNY 1/4 - 20 ZN	2	-
18	34486	Elbow	2	N	80815	HHCS M10 X 30 8.8 ZN	8	38
19	47295	Tube	1	O	80804	WSHRL M10 SPLIT ZN	8	-
20	32315	Pump Hydraulic	1					
21	42987	Heat Shield	1					
22	48366	Cable Batery 10" Red	1					
23	42904	Oil Filler	1					
24	42976	Gasket Filler Oil	1					
25	43019	Water Separator Bracket	1					

**REMARK:** \* Loctite Required

# Piping Diagram Manual

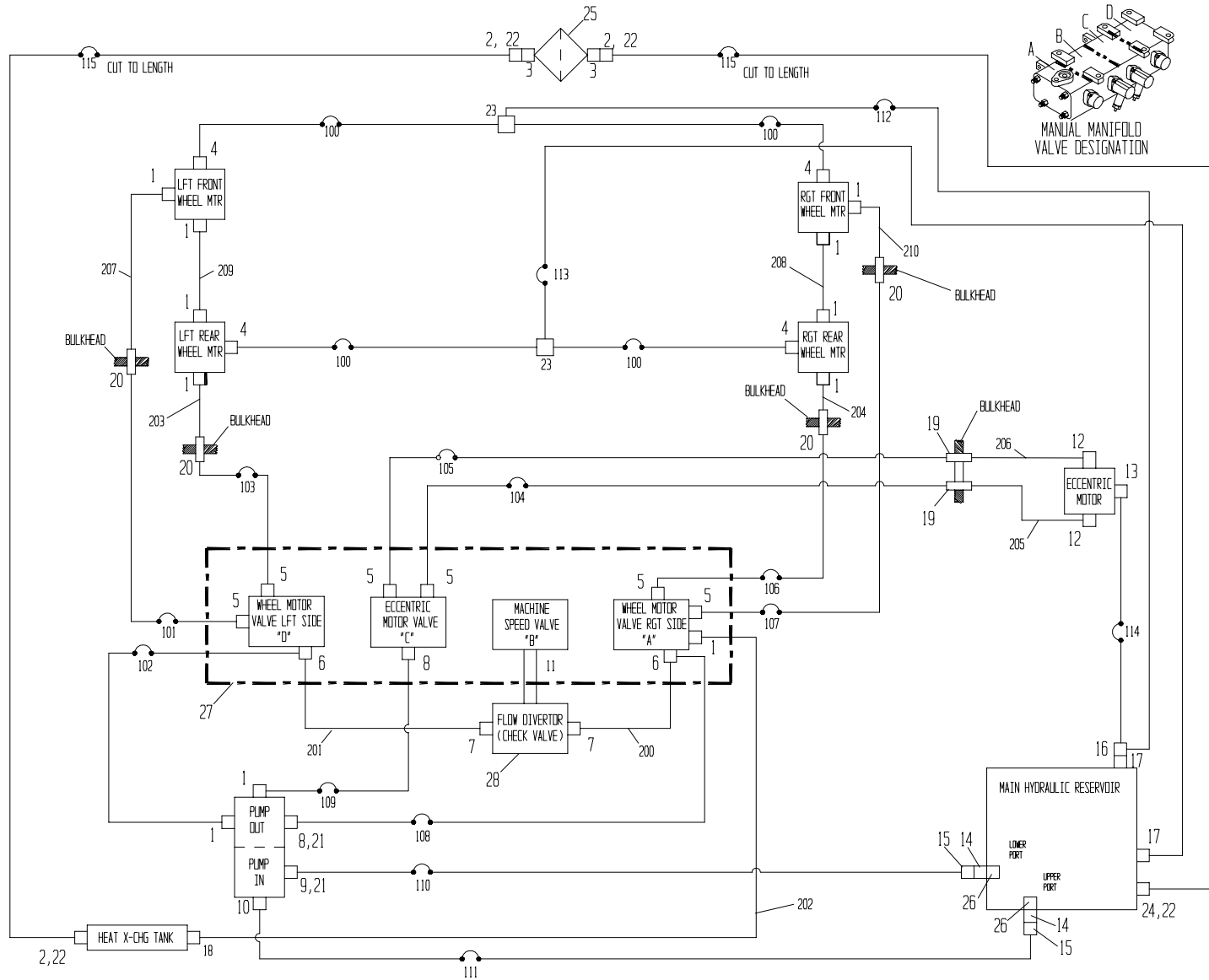

## Piping Diagram Manual - Hose and Tube Assemblies

Item	Part No.	Description	Qty.	Item	Part No.	Description	Qty.	
100	46637	Hose Low Press. Case Drain	1/4" - 6"	4	1	46585	Straight THD Connector 7/8 - 14 O-Ring	11
101	46596	HoseHigh Press. Working	1/2" - 28"	1	2	46592	90° El 1" NPT to Beaded Hose Stem	3
102*	46767	Hose High Press. Working (Twin)	1/2" - 25.25"	1	3	46591	Femal PipeTHD Reducer 1-1/4" to 1"	2
103	46601	Hose High Press. Working	1/2" - 21"	1	4	46631	Straight THD Connector 7/16 - 20 O-Ring	4
104	46755	HoseHigh Press. Working	1/2" - 22"	1	5	46579	Straight THD Connector 3/4 - 16 O-Ring	6
105	46604	HoseHigh Press. Working	1/2" - 25"	1	6	46606	Straight THD Run Tee 7/8 - 14 O-Ring	2
106	46756	HoseHigh Press. Working	1/2" - 17.5"	1	7	46581	Straight THD Elbow 90° 3/4 - 16 O-Ring	2
107	46600	HoseHigh Press. Working	1/2" - 22.5"	1	8	46582	Straight THD Elbow 90° 7/8 - 14 O-Ring	2
108*	46768	HoseHigh Press. Pump	1/2" - 18.50"	1	9	46583	Straight THD Connector 1-1/16 - 12 O-Ring	1
109	46598	HoseHigh Press. Pump	1/2" - 28"	1	10	46584	Straight THD Elbow 90° 1-1/16 - 12 O-Ring	1
110	46578	HoseLow Press. Suction	3/4" - 17"	1	11	46605	Straight THD Con-Manf to Flow Diverter Vlv	1
111*	46769	HoseLow Press. Suction	3/4" - 13.75"	1	12	46617	Straight THD Elbow 90° 1-1/16 - 12 O-Ring	2
112	46763	HoseLow Press. Case Drain	1/4" - 31"	1	13	46632	Male Pipe THD Connector 1/4-18 NPTF	1
113	46636	HoseLow Press. Case Drain	1/4" - 15"	1	14	46590	Female Pipe THD Reducer 1-1/4 X 3/4	2
114	46764	HoseLow Press. Case Drain	1/4" - 8.5"	1	15	46586	Male Pipe Elbow 90° 3/4 - 14 NPTF	2
115	46594	HoseLow Press. Return Line	1" - 64"	1	16	46589	Swivel Nut Branch Tee 1/4" Line Size	1
200	46620	Tube	1/2" O.D.	1	17	46587	Male Pipe THD Straight Connector 1/4 - 18 NPTF	2
201	46621	Tube	1/2" O.D.	1	18	46674	FTG EL 90 3/4 NPT 13/16 ORF	1
202	46720	Tube	1/2" O.D.	1	19	46619	Bulkhead Union (Straight) 1/2" Line Size	2
203	46623	Tube	1/2" O.D.	1	20	46618	Bulkhead Union Elbow 90° 1/2" Line Size	4
204	46624	Tube	1/2" O.D.	1	21	46770	FTG ROCR 1 5/8 OR 1 1/16 OR	2
205	46625	Tube	1/2" O.D.	1	22	46595	Clamp Hose Worm Thd	4
206	46626	Tube	1/2" O.D.	1	23	46633	Union Tee 1/4 Line Size	2
207	46627	Tube	1/2" O.D.	1	24	46593	Straight 1" NPT to Beaded Hose Stem	1
208	46628	Tube	1/2" O.D.	1	25	38636	Hydraulic Fluid Filter	1
209	46629	Tube	1/2" O.D.	1		38638	Element Only	1
210	46630	Tube	1/2" O.D.	1	26	35482	Hydraulic Strainer 25 GPM	2
					27	38668	Manifold Manual	1
					28	38716	Check Valve Manifold	1

**REMARK:** \* Required for new pump.



# Piping Diagram Remote

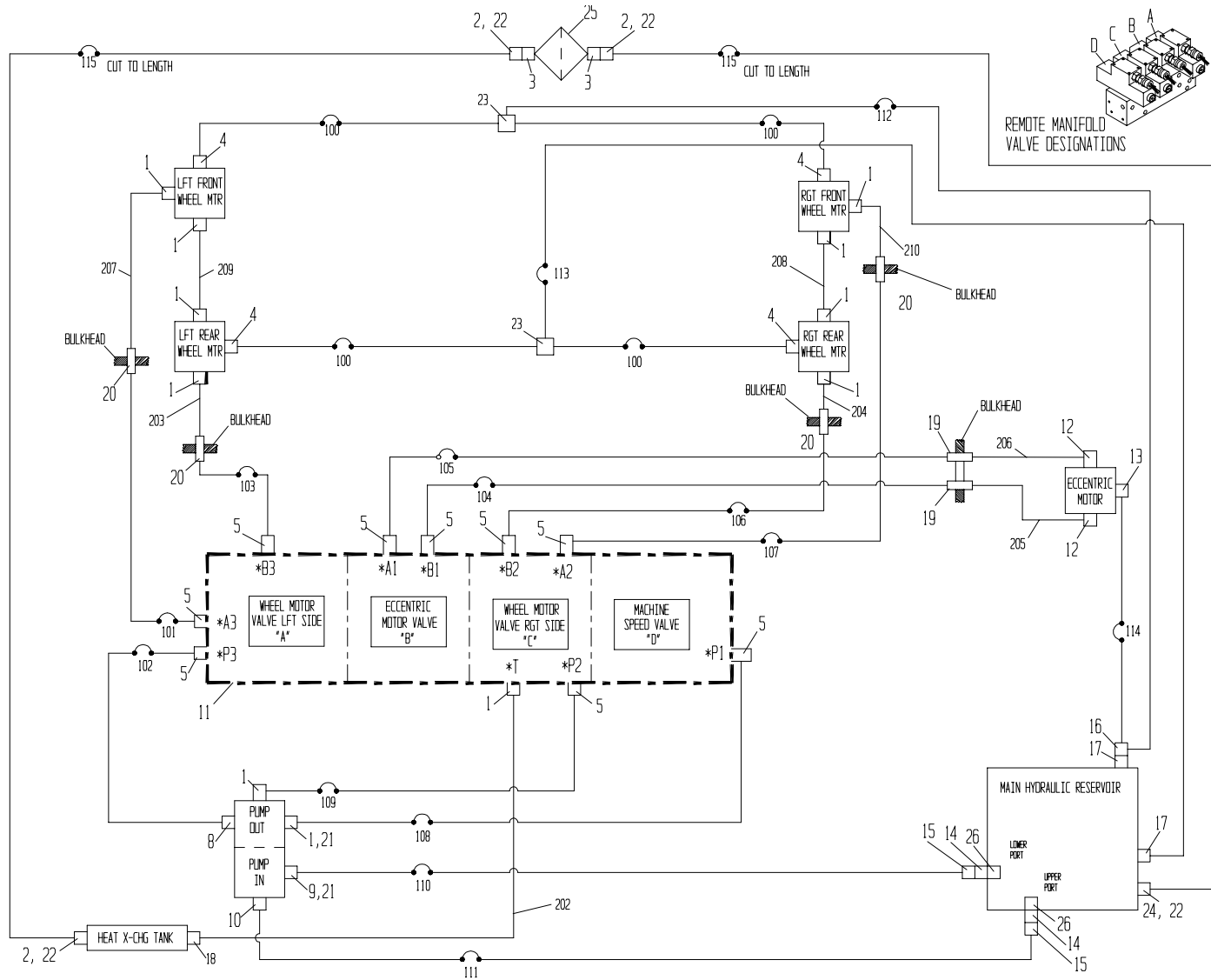

RD014D

## Piping Diagram Remote - Hose and Tube Assemblies

Item	Part No.	Description	Qty.	Item	Part No.	Description	Qty.
100	46637	Hose Low Press. Case Drain 1/4" - 6"	4	1	46585	Straight THD Connector 7/8 - 14 O-RING	11
101	46747	Hose High Press. Working 1/2" - 20.5"	1	2	46592	90° EL 1" NPT TO Beaded Hose Stem	3
102	46765	Hose High Press. Working 1/2" - 23"	1	3	46591	Femal Pipe THD Reducer 1-1/4" TO 1"	2
103	46746	Hose High Press. Working 1/2" - 21.5"	1	4	46631	Straight THD Connector 7/16 - 20 O-Ring	4
104	46748	Hose High Press. Working 1/2" - 21.5"	1	5	46579	Straight THD Connector 3/4 - 16 O-Ring	9
105	46762	Hose High Press. Working 1/2" - 19.5"	1	8	46582	Straight THD ELBOW 90° 7/8 - 14 O-Ring	1
106	46752	Hose High Press. Working 1/2" - 17.5"	1	9	46583	Straight THD Connector 1-1/16 - 12 O-Ring	1
107	46753	Hose High Press. Working 1/2" - 18.5"	1	10	46584	Straight THD ELBOW 90° 1-1/16 - 12 O-Ring	1
108	46751	Hose High Press. Pump 1/2" - 24"	1	11	39306	Manifold Remote	1
109	46766	Hose High Press. Pump 1/2" - 20.75"	1	12	46617	FTG EL 90 1-1/16 OR 1-3/16 ORF	2
110	46578	Hose Low Press. Suction 3/4" - 17"	1	13	46632	Male Pipe Connector 1/4 - 18 NPTF	1
111	46769	Hose Low Press. Suction 3/4" - 13.75"	1	14	46590	Femal Pipe THD REDUCER 1-1/4 X 3/4	2
112	46763	Hose Low Press. Case Drain 1/4" - 31"	1	15	46586	Male Pipe Elbow 90° 3/4 - 14 NPTF	2
113	46636	Hose Low Press. Case Drain 1/4" - 15"	1	16	46589	Swivel Nut Branch Tee 1/4" Line Size	1
114	46764	Hose Low Press. Case Drain 1/4" - 8.5"	1	17	46587	Male Pipe THD Straight Connector 1/4 - 18 NPTF	2
115	46594	Hose Low Press. Return Line 1" -64"	1	18	46588	Male Pipe THD Straight Connector 3/4 - 14 NPTF	1
202	46754	Hose High Press. Return Line 1/2" - 21"	1	19	46619	Bulkhead Union (Straight ) 1/2" Line Size	2
203	46623	Tube 1/2" O.D.	1	20	46618	Bulkhead Union Elbow 90° 1/2" Line Size	4
204	46624	Tube 1/2" O.D.	1	21	46770	FTG ROCR 1 5/8 OR 1 1/16 OR	2
205	46625	Tube 1/2" O.D.	1	22	46595	Clamp Hose Worm THD	4
206	46626	Tube 1/2" O.D.	1	23	46633	Union Tee 1/4 Line Size	2
207	46627	Tube 1/2" O.D.	1	24	46593	Straight 1" NPT To Beaded Hose Stem	1
208	46628	Tube 1/2" O.D.	1	25	38636	Hydraulic Fluid Filter	1
209	46629	Tube 1/2" O.D.	1		38638	Element Only	-
210	46630	Tube 1/2" O.D.	1	26	35482	Hydraulic Strainer 25 GPM/19 l/min	2

**REMARK:** \* Required for New Pump

# Hatz Wire Diagram Manual

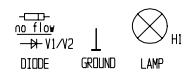
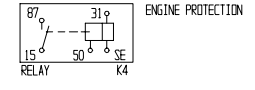
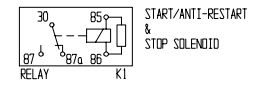
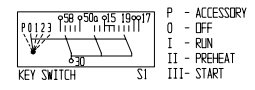
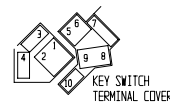
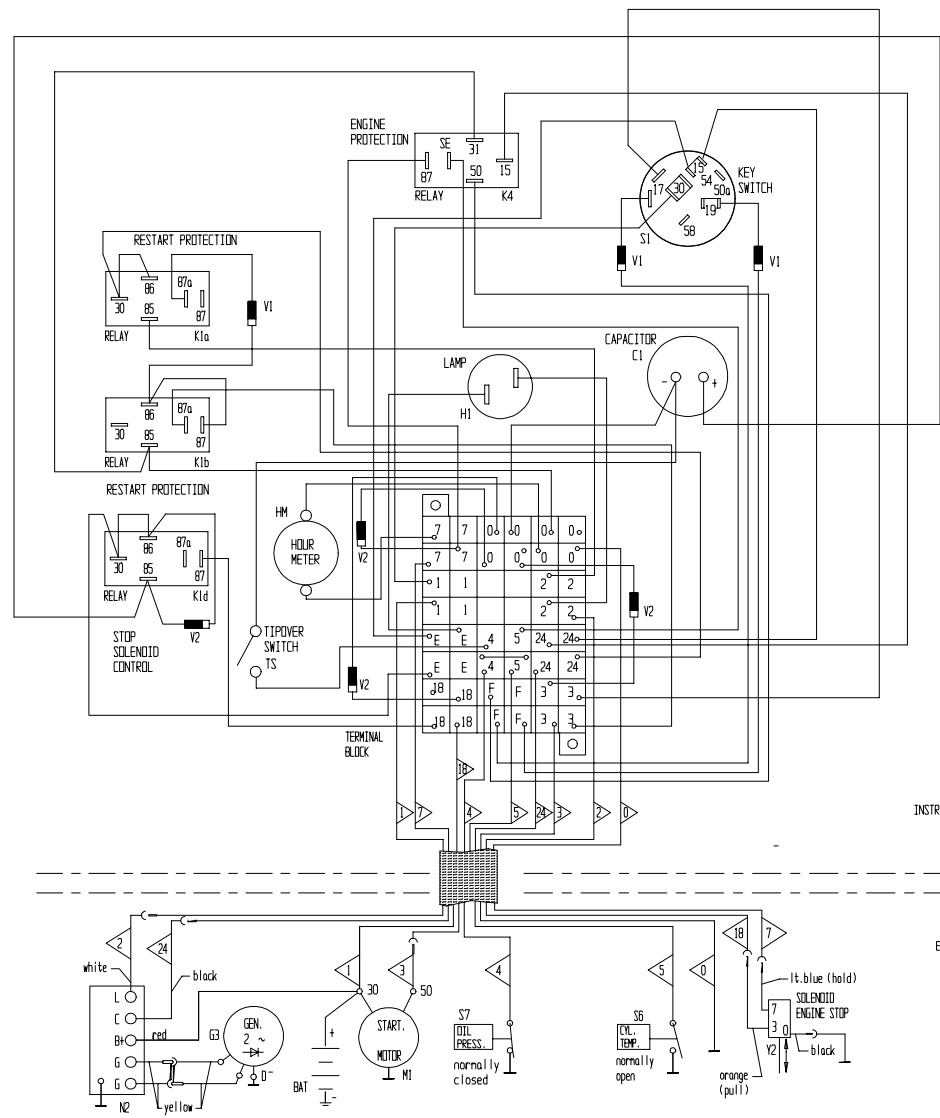

### LEGEND

- C1 CAPACITOR
- G3 ALTERNATOR (FLYWHEEL)
- H1 INDICATOR LAMP 12V 2W
- K1a RELAY - RESTART PROTECTION
- K1b RELAY - RESTART PROTECTION
- K1d RELAY - STOP SOLENOID
- K4 RELAY - ENGINE PROTECTION
- M1 STARTER MOTOR
- N2 REGULATOR
- S1 KEY SWITCH START
- S6 TEMPERATURE SWITCH
- S7 LOW OIL PRESSURE SWITCH
- V1 DIODE - IN4007
- V2 DIODE - IN4007
- X1 TERMINAL STRIP
- X2 MULTI-BLADE CONNECTOR
- Y2 SOLENOID - FUEL SHUTDOWN P/N 39655
- Y2 GAS CYLINDER - ABSORBER P/N 39656
- HM HOUR METER
- TS TIPOVER SWITCH

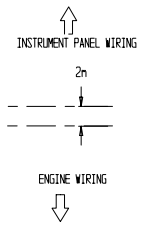

R00130

# Hatz Wire Diagram Remote

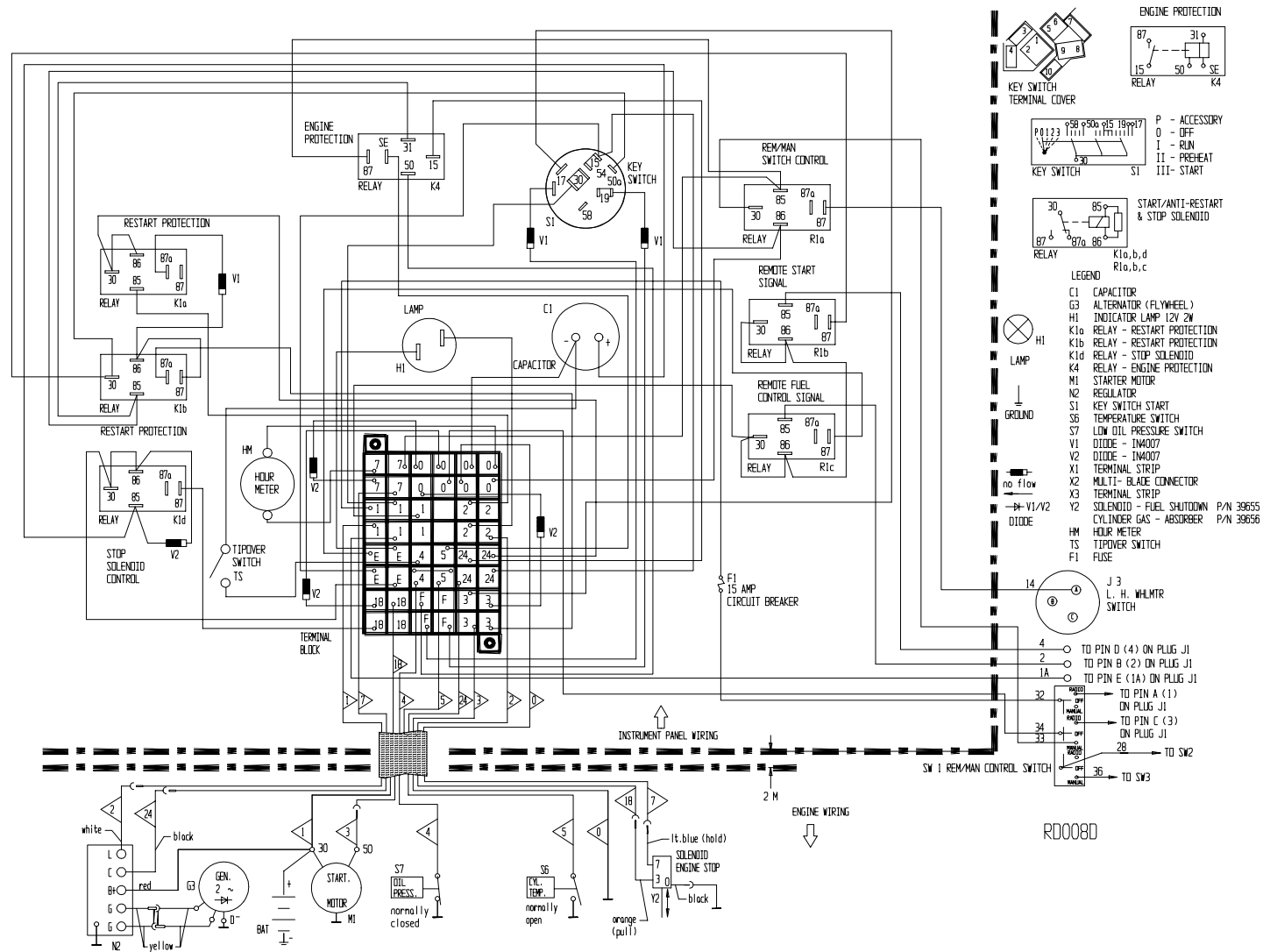

# Manifold Wire Diagram Remote

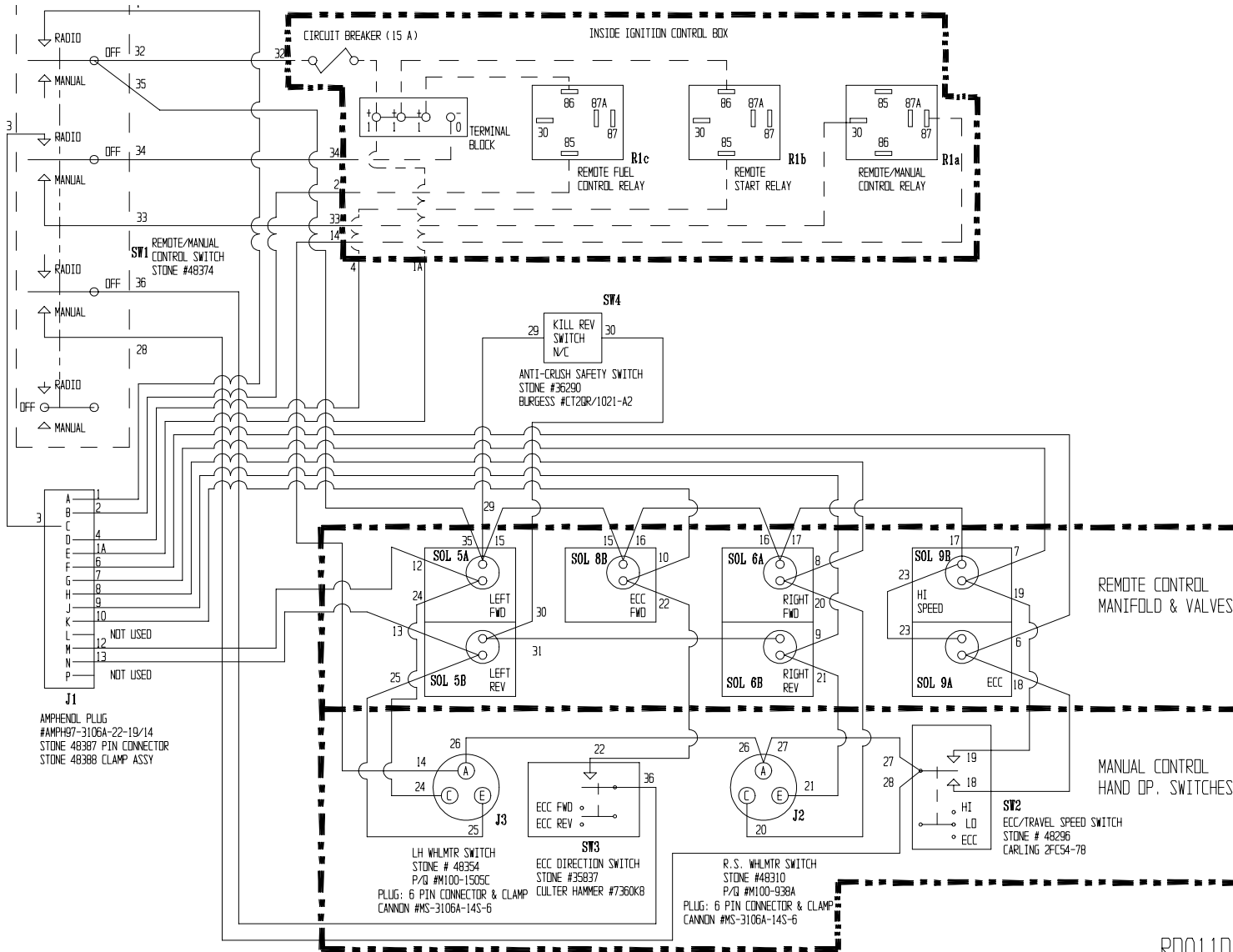

R0011D

# Manifold Wire Diagram Remote

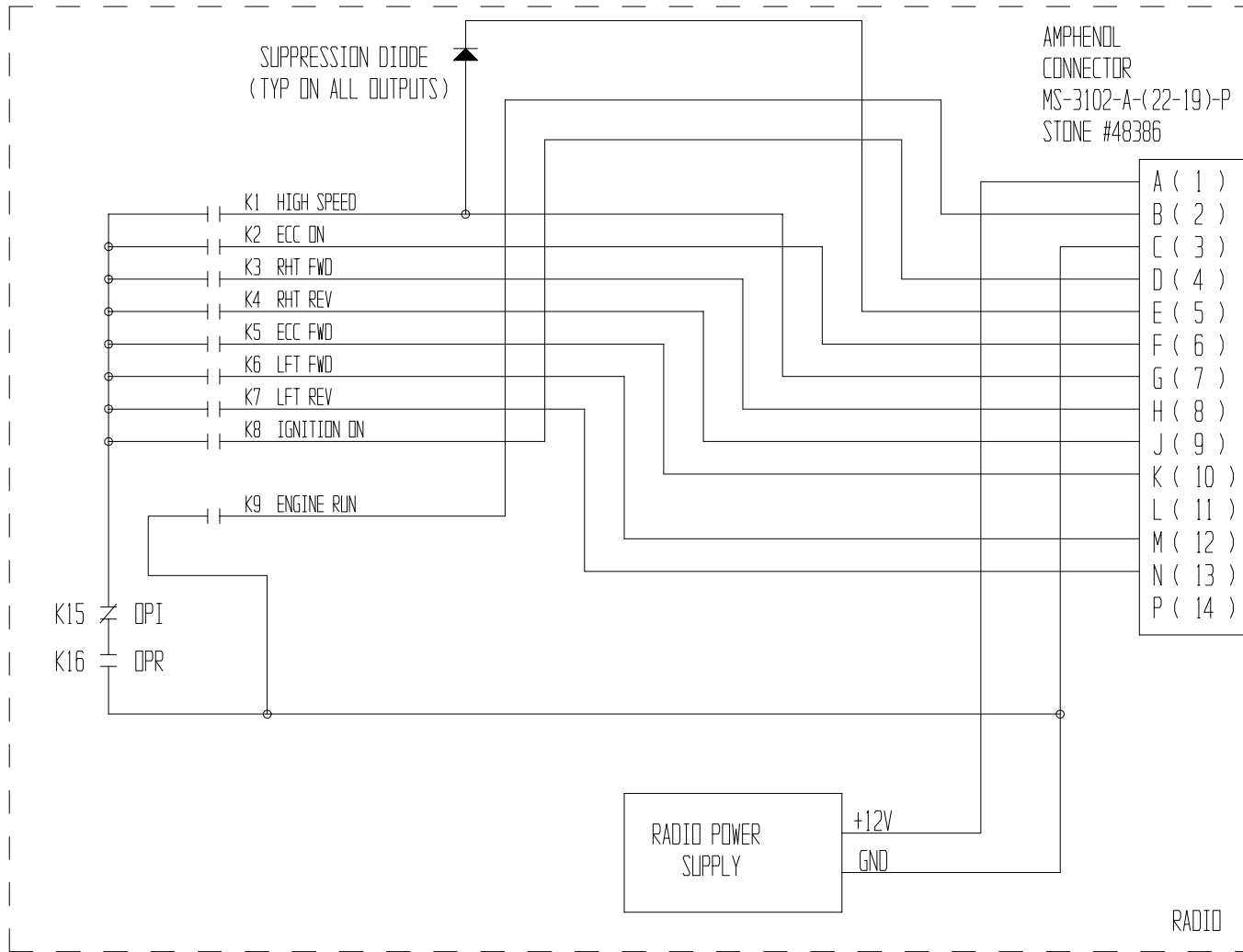

RD012C

REMARK:

# Hydraulic Diagram Manual

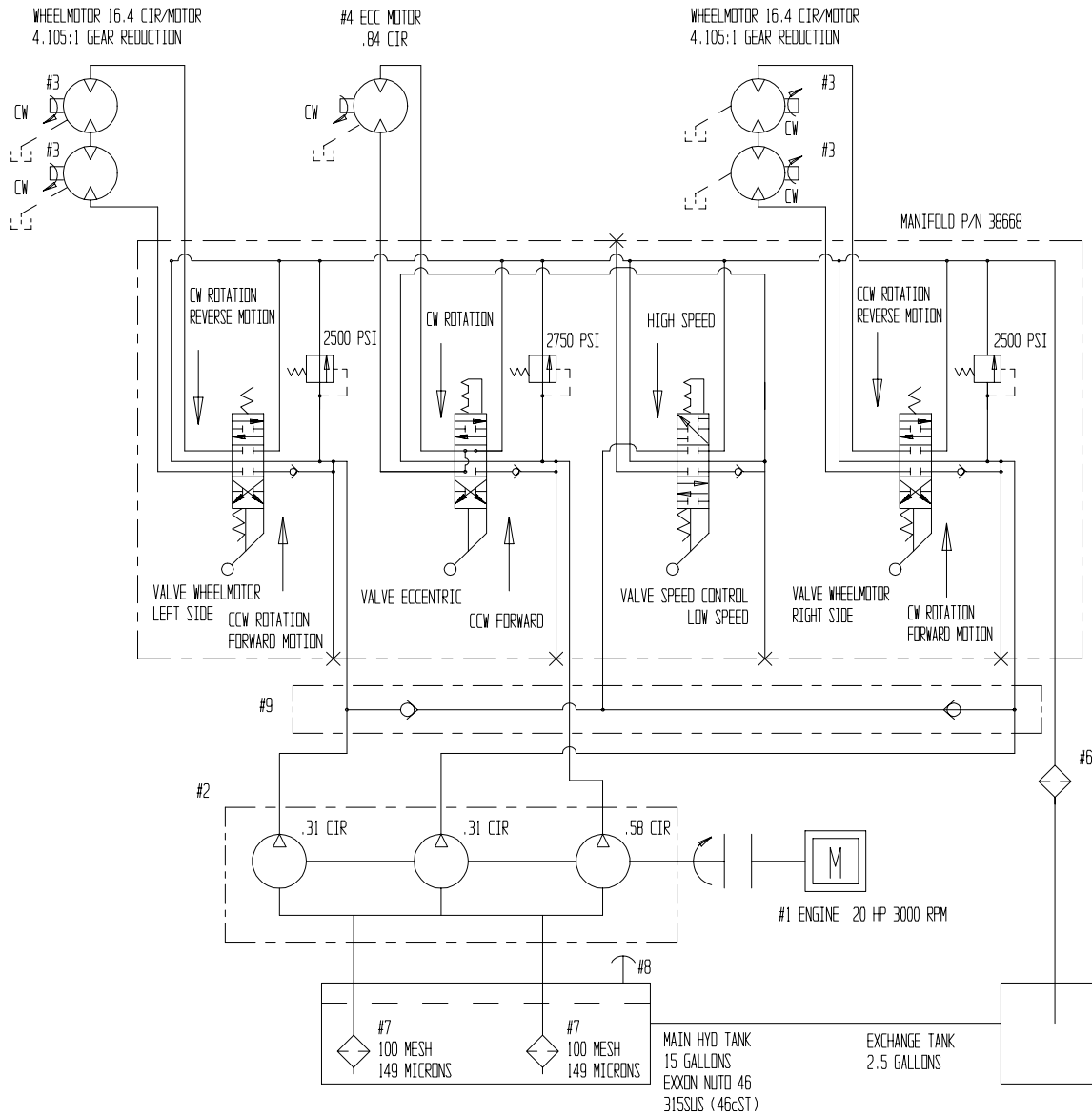

# Hydraulic Diagram Manual

Item	Part No.	Description	Qty.	Item	Part No.	Description	Qty.	Torque (Lb.Ft.)
1	30328	Hatz Twin 2G40 Diesel Engine	1					
2	32273	Hydraulic Pump	1					
3	30270	Torque Hub Wheelmotor	4					
4	30271	Hydraulic Motor Eccentric	1					
5	38668	Manifold Assy Manual	1					
6	38636	Hydraulic Filter	1					
	38638	Element	1					
7	35482	Strainer	2					
8	38521	Breather	1					
9	38716	Flow Diverter Block	1					

REMARK:



# Hydraulic Diagram Remote

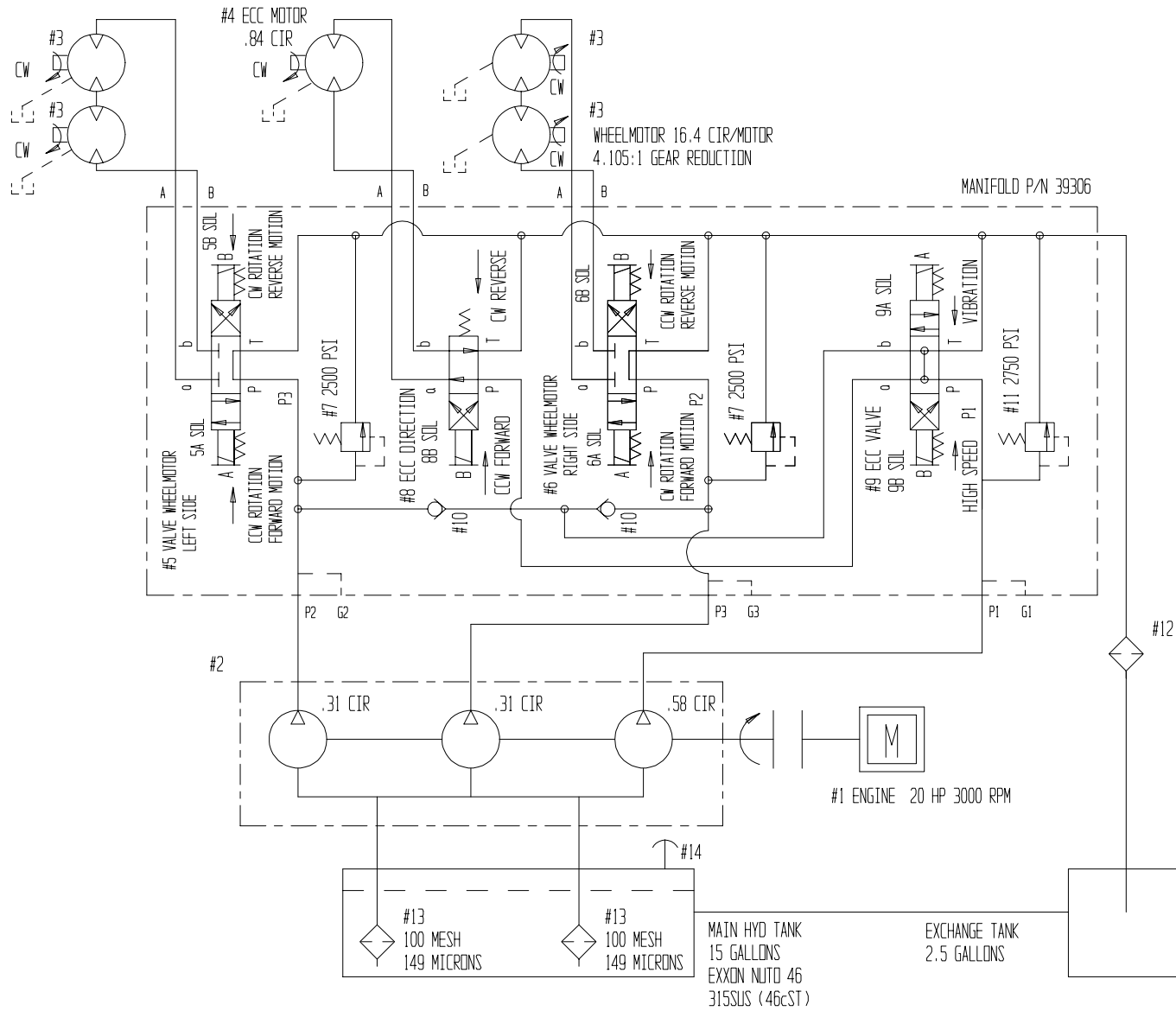

## Hydraulic Diagram Remote

Item	Part No.	Description	Qty.	Item	Part No.	Description	Qty.	Torque (Lb.Ft.)
1	30328	Hatz Twin 2G40 Diesel Engine	1					
2	32273	Hydraulic Pump	1					
3	30270	Torque Hub Wheelmotor	4					
4	30271	Hydraulic Motor Eccentric	1					
*	39306	Manifold Assy Remote	1					
5	48340	Valve F/R Direction Left	1					
6	48340	Valve F/R Direction Right	1					
7	48384	Relief Valve	2					
8	48341	Valve Ecc On/Off	1					
9	48342	Valve Hi/Lo Speed	1					
10	48385	Check Valve	2					
11	48383	Relief Valve	1					
12	38636	Hydraulic Filter	1					
13	35482	Strainer	2					
14	38521	Breather	1					

**REMARK:** \* Assembly includes items 5-11

# Remote Transmitter/Receiver

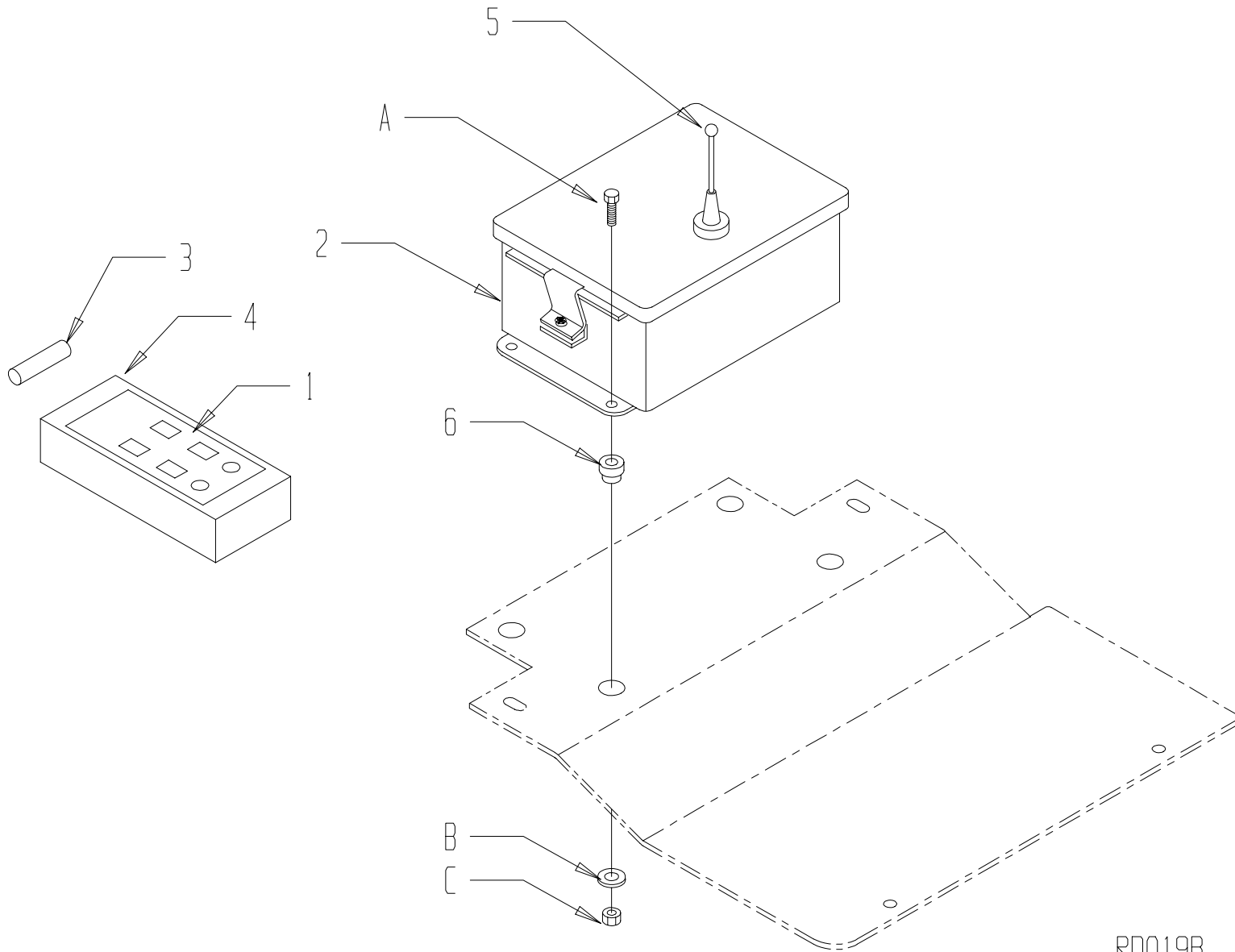

## Remote Transmitter/Receiver

Item	Part No.	Description	Qty.	Item	Part No.	Description	Qty.	Torque (Ft. Lbs.)
	<b>48370</b>	<b>Set Transmitter/Receiver</b>						
1	48368	Transmitter	1	A	80176	HHCS 3/8-16 x 1-1/2 GR5 ZN	4	
2	48369	Receiver	1	B	80043	WSHR 3/8 WROT ZN	4	
3	48371	Battery Alkaline AA	1	C	80056	NUTNY 3/8-16 ZN	4	
4	48372	Case Leather	1					
5	48373	Antenna	1					
6	47355	Shock Mount	4					

REMARK:

## Decal Identification

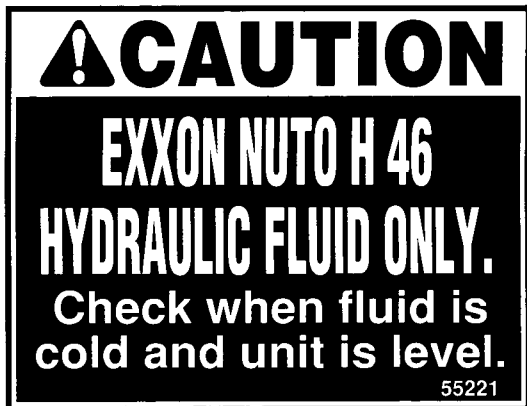

Loc:Hydraulic Tank

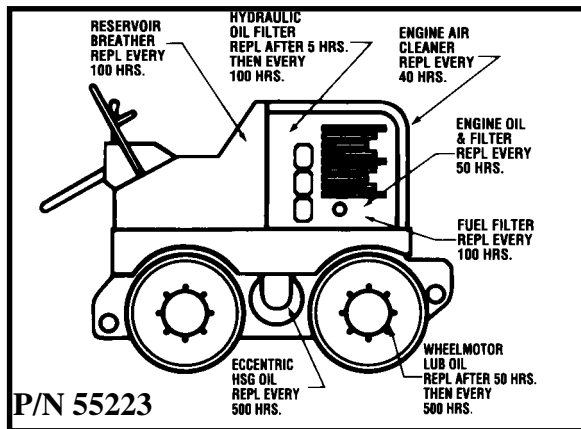

Loc:Hydraulic Tank



Loc:Rear Cover

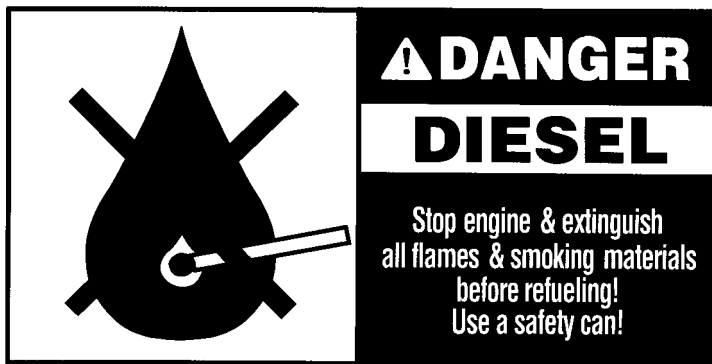

Loc:Fuel Tank

P/N 55148

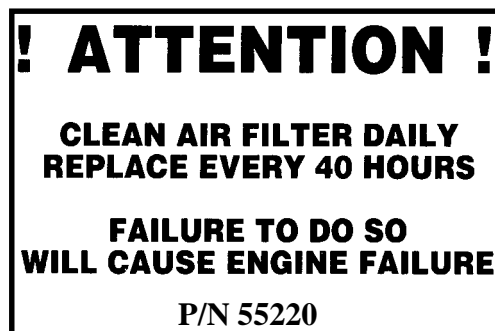

Loc:Air Filter



Loc:Lifteye

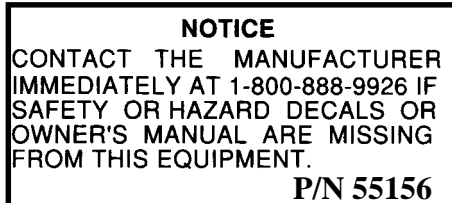

Loc:Rear Cover

# Decal Identification

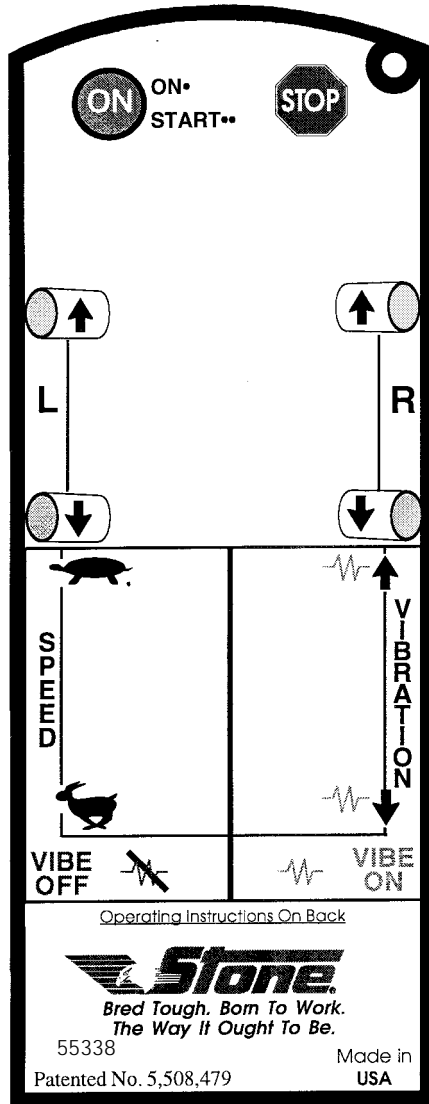

Loc:Transmitter Front

**TRANSMITTER OPERATION**

For transmitter to control machine:  
Manual/Remote switch must be in forward (Remote) position. This switch is located on machine console.

**START:** Depress on/Start button. Must press twice. Initial push energizes engine fuel solenoid. Second push cranks starter.

**STOP:** Depress Off/E-Stop button. De-energizes fuel solenoid.

**MACHINE MOTION:** Left & Right hand drum rocker switches will control Forward & Reverse movement. Must be held down when operating. Movement ceases when switches are released.

**VIBRATION ON:** Depressing vibe on switch starts compaction and controls direction of eccentric weight.

**VIBRATION OFF/TRAVEL SPEED:** Depressing Vibe Off/Speed switch will immediately turn vibration off & put machine into either low or high travel speed.

55342

Loc:Transmitter Back

Manual Machine  
Loc:Lever Cover

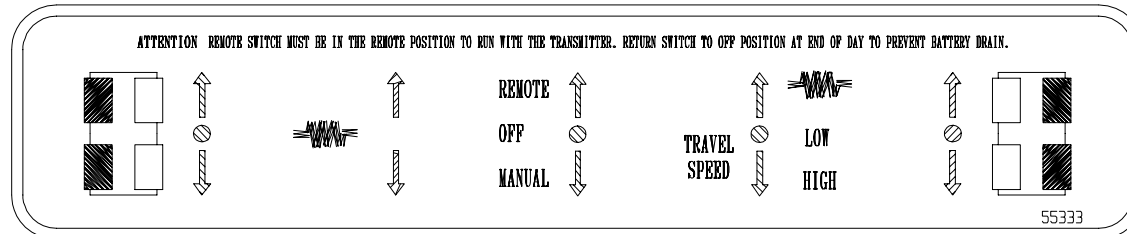
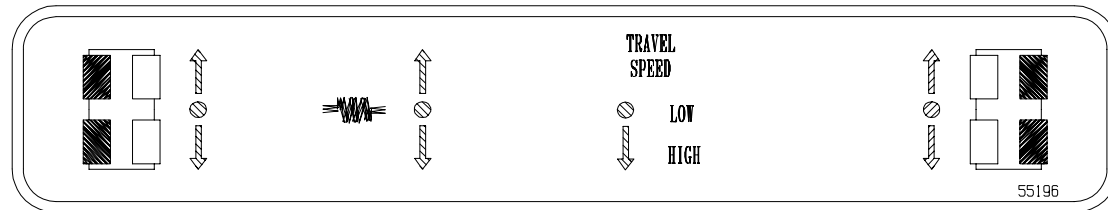

Remote Machine  
Loc:Lever Cover

REMARK: